

© Copyright SEK. Reproduction in any form without permission is prohibited.

Programmerbara styrsystem – Del 6: Funktionssäkerhet

*Programmable controllers –
Part 6: Functional safety*

Som svensk standard gäller europastandarden EN 61131-6:2012. Den svenska standarden innehåller den officiella engelska språkversionen av EN 61131-6:2012.

Nationellt förord

Europastandarden EN 61131-6:2012

består av:

- **europastandardens ikraftsättningsdokument**, utarbetat inom CENELEC
- **IEC 61131-6, First edition, 2012 - Programmable controllers - Part 6: Functional safety**

utarbetad inom International Electrotechnical Commission, IEC.

ICS 25.040.40; 35.240.50

Denna standard är fastställd av SEK Svensk Elstandard, som också kan lämna upplysningar om **sakinnehållet** i standarden.
Postadress: SEK, Box 1284, 164 29 KISTA
Telefon: 08 - 444 14 00. Telefax: 08 - 444 14 30
E-post: sek@elstandard.se. Internet: www.elstandard.se

Standarder underlättar utvecklingen och höjer elsäkerheten

Det finns många fördelar med att ha gemensamma tekniska regler för bl a säkerhet, prestanda, dokumentation, utförande och skötsel av elprodukter, elanläggningar och metoder. Genom att utforma sådana standarder blir säkerhetskraven tydliga och utvecklingskostnaderna rimliga samtidigt som marknadens acceptans för produkten eller tjänsten ökar.

Många standarder inom elområdet beskriver tekniska lösningar och metoder som åstadkommer den elsäkerhet som föreskrivs av svenska myndigheter och av EU.

SEK är Sveriges röst i standardiseringsarbetet inom elområdet

SEK Svensk Elstandard svarar för standardiseringen inom elområdet i Sverige och samordnar svensk medverkan i internationell och europeisk standardisering. SEK är en ideell organisation med frivilligt deltagande från svenska myndigheter, företag och organisationer som vill medverka till och påverka utformningen av tekniska regler inom elektrotekniken.

SEK samordnar svenska intressenters medverkan i SEKs tekniska kommittéer och stödjer svenska experters medverkan i internationella och europeiska projekt.

Stora delar av arbetet sker internationellt

Utformningen av standarder sker i allt väsentligt i internationellt och europeiskt samarbete. SEK är svensk nationalkommitté av International Electrotechnical Commission (IEC) och Comité Européen de Normalisation Electrotechnique (CENELEC).

Standardiseringsarbetet inom SEK är organiserat i referensgrupper bestående av ett antal tekniska kommittéer som speglar hur arbetet inom IEC och CENELEC är organiserat.

Arbetet i de tekniska kommittéerna är öppet för alla svenska organisationer, företag, institutioner, myndigheter och statliga verk. Den årliga avgiften för deltagandet och intäkter från försäljning finansierar SEKs standardiseringsverksamhet och medlemsavgift till IEC och CENELEC.

Var med och påverka!

Den som deltar i SEKs tekniska kommittéarbete har möjlighet att påverka framtida standarder och får tidig tillgång till information och dokumentation om utvecklingen inom sitt teknikområde. Arbetet och kontakterna med kollegor, kunder och konkurrenter kan gynnsamt påverka enskilda företags affärsutveckling och bidrar till deltagarnas egen kompetensutveckling.

Du som vill dra nytta av dessa möjligheter är välkommen att kontakta SEKs kansli för mer information.

SEK Svensk Elstandard

Box 1284
164 29 Kista
Tel 08-444 14 00
www.elstandard.se

English version

**Programmable controllers -
Part 6: Functional safety
(IEC 61131-6:2012)**

Automates programmables -
Partie 6: Sécurité fonctionnelle
(CEI 61131-6:2012)

Speicherprogrammierbare Steuerungen –
Teil 6: Funktionale Sicherheit
(IEC 61131-6:2012)

This European Standard was approved by CENELEC on 2012-11-06. CENELEC members are bound to comply with the CEN/CENELEC Internal Regulations which stipulate the conditions for giving this European Standard the status of a national standard without any alteration.

Up-to-date lists and bibliographical references concerning such national standards may be obtained on application to the CEN-CENELEC Management Centre or to any CENELEC member.

This European Standard exists in three official versions (English, French, German). A version in any other language made by translation under the responsibility of a CENELEC member into its own language and notified to the CEN-CENELEC Management Centre has the same status as the official versions.

CENELEC members are the national electrotechnical committees of Austria, Belgium, Bulgaria, Croatia, Cyprus, the Czech Republic, Denmark, Estonia, Finland, Former Yugoslav Republic of Macedonia, France, Germany, Greece, Hungary, Iceland, Ireland, Italy, Latvia, Lithuania, Luxembourg, Malta, the Netherlands, Norway, Poland, Portugal, Romania, Slovakia, Slovenia, Spain, Sweden, Switzerland, Turkey and the United Kingdom.

CENELEC

European Committee for Electrotechnical Standardization
Comité Européen de Normalisation Electrotechnique
Europäisches Komitee für Elektrotechnische Normung

Management Centre: Avenue Marnix 17, B - 1000 Brussels

Foreword

The text of document 65B/831/FDIS, future edition 1 of IEC 61131-6, prepared by SC 65B, "Devices & process analysis", of IEC TC 65, "Industrial-process measurement, control and automation" was submitted to the IEC-CENELEC parallel vote and approved by CENELEC as EN 61131-6:2012.

The following dates are fixed:

- latest date by which the document has to be implemented at national level by publication of an identical national standard or by endorsement (dop) 2013-08-06
- latest date by which the national standards conflicting with the document have to be withdrawn (dow) 2015-11-06

Attention is drawn to the possibility that some of the elements of this document may be the subject of patent rights. CENELEC [and/or CEN] shall not be held responsible for identifying any or all such patent rights.

Endorsement notice

The text of the International Standard IEC 61131-6:2012 was approved by CENELEC as a European Standard without any modification.

In the official version, for Bibliography, the following notes have to be added for the standards indicated:

IEC 60300-3-2:2004	NOTE	Harmonized as EN 60300-3-2:2005 (not modified).
IEC 61000 series	NOTE	Harmonized in EN 61000 series (not modified).
IEC 61025:2006	NOTE	Harmonized as EN 61025:2007 (not modified).
IEC 61069-7:1999	NOTE	Harmonized as EN 61069-7:1999 (not modified).
IEC 61078:2006	NOTE	Harmonized as EN 61078:2006 (not modified).
IEC 61131-3:2003	NOTE	Harmonized as EN 61131-3:2003 (not modified).
IEC 61165:2006	NOTE	Harmonized as EN 61165:2006 (not modified).
IEC 61496-1:2004 + A1:2007	NOTE	Harmonized as EN 61496-1:2004 (modified) + A1:2008 (not modified).
IEC 61496-3:2008	NOTE	Harmonized as CLC/TS 61496-3:2008 (not modified).
IEC 61508 series	NOTE	Harmonized in EN 61508 series (not modified).
IEC 61508-4:2010	NOTE	Harmonized as EN 61508-4:2010 (not modified).
IEC 61508-5:2010	NOTE	Harmonized as EN 61508-5:2010 (not modified).
IEC 61508-7:2010	NOTE	Harmonized as EN 61508-7:2010 (not modified).
IEC 61511-1:2003	NOTE	Harmonized as EN 61511-1:2004 (not modified).
IEC 61511-2:2003	NOTE	Harmonized as EN 61511-2:2004 (not modified).
IEC 61511-3:2003	NOTE	Harmonized as EN 61511-3:2004 (not modified).

IEC 62061:2005	NOTE	Harmonized as EN 62061:2005 (not modified).
IEC 62079:2001	NOTE	Harmonized as EN 62079:2001 (not modified).
CISPR 11:2009	NOTE	Harmonized as EN 55011:2009 (modified).
ISO 8402:1994	NOTE	Harmonized as EN ISO 8402:1995 (not modified).
ISO 9000-3:1997	NOTE	Harmonized as EN ISO 9000-3:1997 (not modified).
ISO 9001:2008	NOTE	Harmonized as EN ISO 9001:2008 (not modified).
ISO 13849-1:2006	NOTE	Harmonized as EN ISO 13849-1:2008 (not modified).
ISO 13849-2:2003	NOTE	Harmonized as EN ISO 13849-2:2003 (not modified).
ISO 14224:2006	NOTE	Harmonized as EN ISO 14224:2006 (not modified).

Annex ZA (normative)

Normative references to international publications with their corresponding European publications

The following documents, in whole or in part, are normatively referenced in this document and are indispensable for its application. For dated references, only the edition cited applies. For undated references, the latest edition of the referenced document (including any amendments) applies.

NOTE When an international publication has been modified by common modifications, indicated by (mod), the relevant EN/HD applies.

<u>Publication</u>	<u>Year</u>	<u>Title</u>	<u>EN/HD</u>	<u>Year</u>
IEC 60947-5-1	2003	Low-voltage switchgear and controlgear - Part 5-1: Control circuit devices and switching elements - Electromechanical control circuit devices	EN 60947-5-1 + corr. July	2004 2005
IEC/TS 61000-1-2	2008	Electromagnetic compatibility (EMC) - Part 1-2: General - Methodology for the achievement of functional safety of electrical and electronic systems including equipment with regard to electromagnetic phenomena	-	-
IEC 61000-4-2	2008	Electromagnetic compatibility (EMC) - Part 4-2: Testing and measurement techniques - Electrostatic discharge immunity test	EN 61000-4-2	2009
IEC 61000-4-3	2006	Electromagnetic compatibility (EMC) - Part 4-3: Testing and measurement techniques - Radiated, radio-frequency, electromagnetic field immunity test	EN 61000-4-3	2006
IEC 61000-4-4	2012	Electromagnetic compatibility (EMC) - Part 4-4: Testing and measurement techniques - Electrical fast transient/burst immunity test	EN 61000-4-4	2012
IEC 61000-4-5 + corr. October	2005 2009	Electromagnetic compatibility (EMC) - Part 4-5: Testing and measurement techniques - Surge immunity test	EN 61000-4-5	2006
IEC 61000-4-6	2008	Electromagnetic compatibility (EMC) - Part 4-6: Testing and measurement techniques - Immunity to conducted disturbances, induced by radio-frequency fields	EN 61000-4-6	2009
IEC 61000-4-8	2009	Electromagnetic compatibility (EMC) - Part 4-8: Testing and measurement techniques - Power frequency magnetic field immunity test	EN 61000-4-8	2010
IEC 61131-1	2003	Programmable controllers - Part 1: General information	EN 61131-1	2003
IEC 61131-2	2007	Programmable controllers - Part 2: Equipment requirements and tests	EN 61131-2	2007
IEC/TR 61131-4	2004	Programmable controllers - Part 4: User guidelines	-	-

<u>Publication</u>	<u>Year</u>	<u>Title</u>	<u>EN/HD</u>	<u>Year</u>
IEC 61326-3-1 + corr. August	2008 2008	Electrical equipment for measurement, control and laboratory use - EMC requirements - Part 3-1: Immunity requirements for safety-related systems and for equipment intended to perform safety-related functions (functional safety) - General industrial applications	EN 61326-3-1	2008
IEC 61326-3-2	2008	Electrical equipment for measurement, control and laboratory use - EMC requirements - Part 3-2: Immunity requirements for safety-related systems and for equipment intended to perform safety-related functions (functional safety) - Industrial applications with specified electromagnetic environment	EN 61326-3-2	2008
IEC 61508-1	2010	Functional safety of electrical/electronic/programmable electronic safety-related systems - Part 1: General requirements	EN 61508-1	2010
IEC 61508-2	2010	Functional safety of electrical/electronic/programmable electronic safety-related systems - Part 2: Requirements for electrical/electronic/programmable electronic safety-related systems	EN 61508-2	2010
IEC 61508-3	2010	Functional safety of electrical/electronic/programmable electronic safety-related systems - Part 3: Software requirements	EN 61508-3	2010
IEC 61508-6	2010	Functional safety of electrical/electronic/programmable electronic safety-related systems - Part 6: Guidelines on the application of IEC 61508-2 and IEC 61508-3	EN 61508-6	2010
IEC 61784-3	2010	Industrial communication networks - Profiles – Part 3: Functional safety fieldbuses - General rules and profile definitions	EN 61784-3	2010
IEC 62443	Series	Security for industrial process measurement and control - Network and system security	-	-
IEC Guide 104	2010	The preparation of safety publications and the use of basic safety publications and group safety publications	-	-
ISO/IEC Guide 51	1999	Safety aspects - Guidelines for their inclusion in standards	-	-
EN 50205	2002	Relays with forcibly guided (mechanically linked) contacts	-	-

CONTENTS

INTRODUCTION.....	8
1 Scope.....	10
2 Normative references	11
3 Terms and definitions	12
4 Conformance to this standard	25
5 FS-PLC safety lifecycle	25
5.1 General	25
5.2 FS-PLC functional safety SIL capability requirements.....	27
5.2.1 General	27
5.2.2 Data security	28
5.3 Quality management system.....	28
5.4 Management of FS-PLC safety lifecycle	29
5.4.1 Objectives	29
5.4.2 Requirements and procedures	29
5.4.3 Execution and monitoring	33
5.4.4 Management of functional safety	33
6 FS-PLC design requirements specification.....	33
6.1 General	33
6.2 Design requirements specification contents.....	34
6.3 Target failure rate.....	35
7 FS-PLC design, development and validation plan	36
7.1 General	36
7.2 Segmenting requirements.....	36
8 FS-PLC architecture	37
8.1 General	37
8.2 Architectures and subsystems	38
8.3 Data communication.....	38
9 HW design, development and validation planning	38
9.1 HW general requirements	38
9.2 HW functional safety requirements specification	38
9.3 HW safety validation planning	38
9.4 HW design and development	39
9.4.1 General	39
9.4.2 Requirements for FS-PLC behaviour on detection of a fault.....	39
9.4.3 HW safety integrity	40
9.4.4 Random HW failures.....	48
9.4.5 HW requirements for the avoidance of systematic failures	53
9.4.6 HW requirements for the control of systematic faults	53
9.4.7 HW classification of faults.....	54
9.4.8 HW implementation	55
9.4.9 De-rating of components.....	56
9.4.10 ASIC design and development.....	56
9.4.11 Techniques and measures to prevent the introduction of faults in ASICs	56

9.5	HW and embedded SW and FS-PLC integration	56
9.6	HW operation and maintenance procedures	57
9.6.1	Objective	57
9.6.2	Requirements	57
9.7	HW safety validation.....	58
9.7.1	General	58
9.7.2	Requirements	58
9.8	HW verification	59
9.8.1	Objective	59
9.8.2	Requirements	59
10	FS-PLC SW design and development	60
10.1	General	60
10.2	Requirements	61
10.3	Classification of engineering tools	61
10.4	SW safety validation planning.....	62
11	FS-PLC safety validation	62
12	FS-PLC type tests	62
12.1	General	62
12.2	Type test requirements	62
12.3	Climatic test requirements	65
12.4	Mechanical test requirements	65
12.5	EMC test requirements	65
12.5.1	General	65
12.5.2	General EMC environment.....	65
12.5.3	Specified EMC environment.....	67
13	FS-PLC verification	69
13.1	Verification plan	69
13.2	Fault insertion test requirements	70
13.3	As qualified versus as shipped	71
14	Functional safety assessment.....	71
14.1	Objective	71
14.2	Assessment requirements	72
14.2.1	Assessment evidence and documentation	72
14.2.2	Assessment method	72
14.3	FS-PLC assessment information.....	74
14.4	Independence.....	74
15	FS-PLC operation, maintenance and modification procedures	75
15.1	Objective	75
15.2	FS-PLC modification.....	75
16	Information to be provided by the FS-PLC manufacturer for the user	76
16.1	General	76
16.2	Information on conformance to this standard	76
16.3	Information on type and content of documentation.....	76
16.4	Information on catalogues and/or datasheets	76
16.5	Safety manual	76
16.5.1	General	76
16.5.2	Safety manual contents	76
Annex A	(informative) Reliability calculations.....	79

Annex B (informative) Typical FS-PLC Architectures.....	80
Annex C (informative) Energise to trip applications of FS-PLC.....	86
Annex D (informative) Available failure rate databases	88
Annex E (informative) Methodology for the estimation of common cause failure rates in a multiple channel FS-PLC.....	90
Bibliography.....	92
Figure 1 – FS-PLC in the overall E/E/PE safety-related system safety lifecycle phases.....	9
Figure 2 – Failure model.....	16
Figure 3 – FS-PLC safety lifecycle (in realization phase)	26
Figure 4 – Relevant parts of a safety function	35
Figure 5 – FS-PLC to engineering tools relationship	37
Figure 6 – HW subsystem decomposition.....	43
Figure 7 – Example: determination of the maximum SIL for specified architecture	45
Figure 8 – Example of limitation on hardware safety integrity for a multiple-channel safety function	47
Figure 9 – Fault classification and FS-PLC behaviour	54
Figure 10 – ASIC development lifecycle (V-Model).....	56
Figure 11 – Model of FS-PLC and engineering tools layers.....	60
Figure B.1 – Single FS-PLC with single I/O and external watchdog (1oo1D)	81
Figure B.2 – Dual PE with single I/O and external watchdogs (1oo1D).....	81
Figure B.3 – Dual PE with dual I/O, no inter-processor communication, and 1oo2 shutdown logic.....	82
Figure B.4 – Dual PE with dual I/O, inter-processor communication, and 1oo2D shutdown logic.....	83
Figure B.5 – Dual PE with dual I/O, no inter-processor communication, external watchdogs, and 2oo2 shutdown logic.....	83
Figure B.6 – Dual PE with dual I/O, inter-processor communication, external watchdogs, and 2oo2D shutdown logic	84
Figure B.7 – Triple PE with triple I/O, inter-processor communication, and 2oo3D shutdown logic.....	85
Table 1 – Safety integrity levels for low demand mode of operation	35
Table 2 – Safety integrity levels for high demand or continuous mode of operation	36
Table 3 – Faults to be detected and notified (alarmed) to the application program	40
Table 4 – Hardware safety integrity – low complexity (type A) subsystem	41
Table 5 – Hardware safety integrity – high complexity (type B) subsystem.....	41
Table 6 – Faults or failures to be assumed when quantifying the effect of random hardware failures or to be taken into account in the derivation of safe failure fraction	50
Table 7 – Examples of tool classification.....	61
Table 8 – Performance criteria.....	64
Table 9 – Immunity test levels for enclosure port tests in general EMC environment.....	66
Table 10 – Immunity test levels in general EMC environment.....	67
Table 11 – Immunity test levels for enclosure port tests in specified EMC environment.....	68
Table 12 – Immunity test levels in specified EMC environment	69
Table 13 – Fault tolerance test, required effectiveness	71

Table 14 – Functional safety assessment Information	74
Table 15 – Minimum levels of independence of those carrying out functional safety assessment	75
Table E.1 – Criteria for estimation of common cause failure.....	90
Table E.2 – Estimation of common cause failure factor	91

INTRODUCTION

General

IEC 61131 series consists of the following parts under the general title *Programmable controllers*:

- Part 1: General information
- Part 2: Equipment requirements and tests
- Part 3: Programming languages
- Part 4: User guidelines
- Part 5: Communications
- Part 6: Functional safety
- Part 7: Fuzzy control programming
- Part 8: Guidelines for the application and implementation of programming languages

This Part of IEC 61131 series constitutes Part 6 of a series of standards on programmable controllers and the associated peripherals and should be read in conjunction with the other parts of the series.

As this document is the FS-PLC product standard, the provisions of this part should be considered to govern in the area of programmable controllers and their associated peripherals.

Compliance with Part 6 of IEC 61131 cannot be claimed unless the requirements of Clause 4 of this part are met.

Terms of general use are defined in Part 1 of IEC 61131. More specific terms are defined in each part.

In keeping with 1.1 of IEC 61508-1:2010, this part encompasses the product specific requirements of IEC 61508-1, 61508-2 and 61508-3 as pertaining to programmable controllers and their associated peripherals.

This document's intent is to follow the IEC 61508 series structure, in principle. But some aspects do not have a direct correlation and thus need to be addressed somewhat differently. In part, this is due to addressing hardware, software, firmware, etc. in a single document.

Framework of this part

IEC 61508-1:2010, Figure 2 is included here, and is designated Figure 1. It has been adjusted to show how an FS-PLC fits into the overall E/E/PE safety-related system safety lifecycle. Though Figure 1 box 10 includes sensors, logic subsystem and final elements (e.g. actuators), from the viewpoint of IEC 61508-1, the FS-PLC is given emphasis here by including a reference to Figure 3.

As such, the Realization Phase, Figure 1, box 10, embodies only the logic subsystem, from this part's perspective.

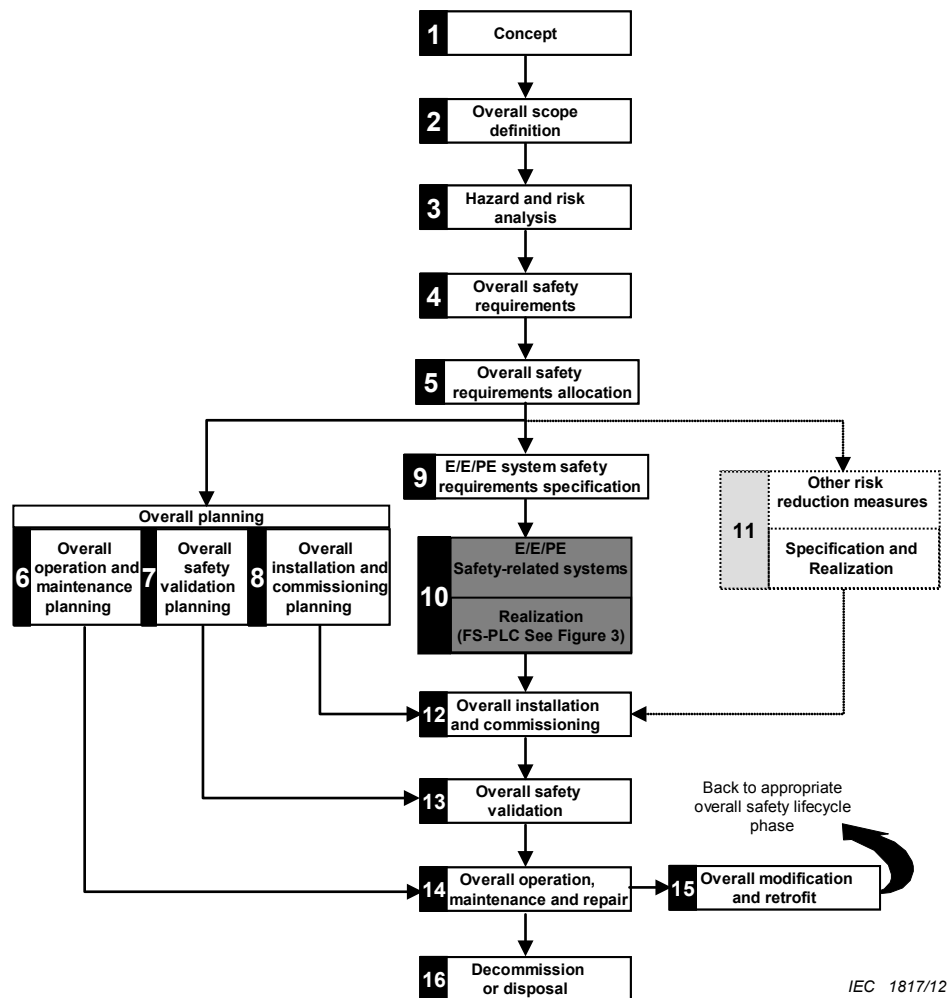

NOTE 1 Activities relating to verification, management of functional safety and functional safety assessment are not shown for reasons of clarity but are relevant to all overall, E/E/PE system and software safety lifecycle phases.

NOTE 2 The phases represented by box 11 is outside the scope of this standard.

NOTE 3 IEC 61508-2 and IEC 61508-3 deal with box 10 (realization) but they also deal, where relevant, with the programmable electronic (hardware and software) aspects of boxes 13, 14 and 15.

NOTE 4 See IEC 61508-1, Table 1 for a description of the objectives and scope of the phases represented by each box.

NOTE 5 The technical requirements necessary for the overall operation, maintenance, repair Modification, retrofit and decommissioning or disposal will be specified as part of the information provided by the supplier of the E/E/PE safety-related system and its elements and components.

Figure 1 – FS-PLC in the overall E/E/PE safety-related system safety lifecycle phases

The areas included in this part are FS-PLC safety lifecycle management, functional safety requirements allocation, and development planning; with the major emphasis on the Realization Phase (Box 10) of the overall safety lifecycle, shown in Figure 1. The assumption of this part is that the FS-PLC is utilized as a logic subsystem for the overall E/E/PE system.

The Figure 1, Realization (box 10), includes:

- the allocation of the FS-PLC safety aspects to FS-PLC hardware, software or firmware, or any combination,
- FS-PLC hardware architectures,
- verification and validation activities at the FS-PLC level,
- FS-PLC modification requirements,
- operation and maintenance information for the FS-PLC user,
- information to be provided by the FS-PLC manufacturer for the user.

PROGRAMMABLE CONTROLLERS –

Part 6: Functional safety

1 Scope

This Part of the IEC 61131 series specifies requirements for programmable controllers (PLCs) and their associated peripherals, as defined in Part 1, which are intended to be used as the logic subsystem of an electrical/electronic/programmable electronic (E/E/PE) safety-related system. A programmable controller and its associated peripherals complying with the requirements of this part is considered suitable for use in an E/E/PE safety-related system and is identified as a functional safety programmable logic controller (FS-PLC). An FS-PLC is generally a hardware (HW) / software (SW) subsystem. An FS-PLC may also include software elements, for example predefined function blocks.

An E/E/PE safety-related system generally consists of sensors, actuators, software and a logic subsystem. This part is a product specific implementation of the requirements of the IEC 61508 series and conformity to this part fulfils all of the applicable requirements of the IEC 61508 series related to FS-PLCs. While the IEC 61508 series is a system standard, this part provides product specific requirements for the application of the principles of the IEC 61508 series to FS-PLC.

This Part of the IEC 61131 series addresses only the functional safety and safety integrity requirements of an FS-PLC when used as part of an E/E/PE safety-related system. The definition of the functional safety requirements of the overall E/E/PE safety-related system and the functional safety requirements of the ultimate application of the E/E/PE safety-related system are outside the scope of this part, but they are inputs for this part. For application specific information the reader is referred to standards such as the IEC 61511 series, IEC 62061, and the ISO 13849 series.

This part does not cover general safety requirements for an FS-PLC such as requirements related to electric shock and fire hazards specified in IEC 61131-2.

This part applies to an FS-PLC with a Safety Integrity Level (SIL) capability not greater than SIL 3.

The objective of this part is:

- to establish and describe the safety life-cycle elements of an FS-PLC, in harmony with the general safety life-cycle identified in IEC 61508-1, -2 and -3;
- to establish and describe the requirements for FS-PLC HW and SW that relate to the functional safety and safety integrity requirements of a E/E/PE safety-related system;
- to establish evaluation methods for a FS-PLC to this part for the following parameters/criteria:
 - a Safety Integrity Level (SIL) claim for which the FS-PLC is capable,
 - a Probability of Failure on Demand (PFD) value,
 - an average frequency of dangerous failure per hour value (PFH),
 - a value for the safe failure fraction (SFF),
 - a value for the hardware fault tolerance (HFT),
 - a diagnostic coverage (DC) value,
 - a verification that the specified FS-PLC manufacturer's safety lifecycle processes are in place,

- the defined safe state,
 - the measures and techniques for the prevention and control of systematic faults, and
 - for each failure mode addressed in this part, the functional behaviour in the failed state;
- to establish the definitions and identify the principal characteristics relevant to the selection and application of FS-PLCs and their associated peripherals.

This part is primarily intended for FS-PLC manufacturers. It also includes the critical role of FS-PLC users through the user documentation requirements. Some user guidelines for FS-PLCs may be found in IEC 61131-4.

The requirements of ISO/IEC Guide 51 and IEC Guide 104, as they relate to this part, are incorporated herein.

2 Normative references

The following documents, in whole or in part, are normatively referenced in this document and are indispensable for its application. For dated references, only the edition cited applies. For undated references, the latest edition of the referenced document (including any amendments) applies.

IEC 60947-5-1:2003, *Low-voltage switchgear and controlgear – Part 5-1: Control circuit devices and switching elements – Electromechanical control circuit devices*

IEC/TS 61000-1-2:2008, *Electromagnetic compatibility (EMC) – Part 1-2: General – Methodology for the achievement of functional safety of electrical and electronic systems including equipment with regard to electromagnetic phenomena*

IEC 61000-4-2:2008, *Electromagnetic compatibility (EMC) – Part 4-2: Testing and measurement techniques – Electrostatic discharge immunity test*

IEC 61000-4-3:2006, *Electromagnetic compatibility (EMC) – Part 4-3: Testing and measurement techniques – Radiated, radio-frequency, electromagnetic field immunity test*

IEC 61000-4-4:2012, *Electromagnetic compatibility (EMC) – Part 4-4: Testing and measurement techniques – Electrical fast transient/burst immunity test*

IEC 61000-4-5:2005, *Electromagnetic compatibility (EMC) – Part 4-5: Testing and measurement techniques – Surge immunity test*

IEC 61000-4-6:2008, *Electromagnetic compatibility (EMC) – Part 4-6: Testing and measurement techniques – Immunity to conducted disturbances, induced by radio-frequency fields*

IEC 61000-4-8:2009, *Electromagnetic compatibility (EMC) – Part 4-8: Testing and measurement techniques – Power frequency magnetic field immunity test*

IEC 61131-1:2003, *Programmable controllers – Part 1: General information*

IEC 61131-2:2007, *Programmable controllers – Part 2: Equipment requirements and tests*

IEC 61131-4:2004, *Programmable controllers – Part 4: User guidelines*

IEC 61326-3-1:2008, *Electrical equipment for measurement, control and laboratory use – EMC requirements – Part 3-1: Immunity requirements for safety-related systems and for*

equipment intended to perform safety-related functions (functional safety) – General industrial applications

IEC 61326-3-2:2008, Electrical equipment for measurement, control and laboratory use – EMC requirements – Part 3-2: Immunity requirements for safety-related systems and for equipment intended to perform safety-related functions (functional safety) – Industrial applications with specified electromagnetic environment

IEC 61508-1:2010, Functional safety of electrical/electronic/programmable electronic safety-related systems – Part 1: General requirements

IEC 61508-2:2010, Functional safety of electrical/electronic/programmable electronic safety-related systems – Part 2: Requirements for electrical/electronic/programmable electronic safety-related systems

IEC 61508-3:2010, Functional safety of electrical/electronic/programmable electronic safety-related systems – Part 3: Software requirements

IEC 61508-6:2010, Functional safety of electrical/electronic/programmable electronic safety-related systems – Part 6: Guidelines on the application of IEC 61508-2 and IEC 61508-3

IEC 61784-3:2010, Industrial communication networks – Profiles – Part 3: Functional safety fieldbuses – General rules and profile definitions

IEC 62443 (all parts), Industrial communication networks – Network and system security

IEC Guide 104:2010, The preparation of safety publications and the use of basic safety publications and group safety publications

ISO/IEC Guide 51:1999, Safety aspects – Guidelines for their inclusion in standards

EN 50205:2002, Relays with forcibly guided (mechanically linked) contacts