

© Copyright SEK. Reproduction in any form without permission is prohibited.

Datahallsutrymmen och tillhörande system – Del 2-3: Inomhusklimat

*Information technology –
Data centre facilities and infrastructures –
Part 2-3: Environmental control*

Som svensk standard gäller europastandarden EN 50600-2-3:2014. Den svenska standarden innehåller den officiella engelska språkversionen av EN 50600-2-3:2014.

ICS 35.020.00; 35.110.00; 35.160.00

Denna standard är fastställd av SEK Svensk Elstandard, som också kan lämna upplysningar om **sakinnehållet** i standarden.
Postadress: Box 1284, 164 29 KISTA
Telefon: 08 - 444 14 00.
E-post: sek@elstandard.se. Internet: www.elstandard.se

Standarder underlättar utvecklingen och höjer elsäkerheten

Det finns många fördelar med att ha gemensamma tekniska regler för bl a mätning, säkerhet och provning och för utförande, skötsel och dokumentation av elprodukter och elanläggningar.

Genom att utforma sådana standarder blir säkerhetsfordringar tydliga och utvecklingskostnaderna rimliga samtidigt som marknadens acceptans för produkten eller tjänsten ökar.

Många standarder inom elområdet beskriver tekniska lösningar och metoder som åstadkommer den elsäkerhet som föreskrivs av svenska myndigheter och av EU.

SEK är Sveriges röst i standardiseringsarbetet inom elområdet

SEK Svensk Elstandard svarar för standardiseringen inom elområdet i Sverige och samordnar svensk medverkan i internationell och europeisk standardisering. SEK är en ideell organisation med frivilligt deltagande från svenska myndigheter, företag och organisationer som vill medverka till och påverka utformningen av tekniska regler inom elektrotekniken.

SEK samordnar svenska intressenters medverkan i SEKs tekniska kommittéer och stödjer svenska experters medverkan i internationella och europeiska projekt.

Stora delar av arbetet sker internationellt

Utformningen av standarder sker i allt väsentligt i internationellt och europeiskt samarbete. SEK är svensk nationalkommitté av International Electrotechnical Commission (IEC) och Comité Européen de Normalisation Electrotechnique (CENELEC).

Standardiseringsarbetet inom SEK är organiserat i referensgrupper bestående av ett antal tekniska kommittéer som speglar hur arbetet inom IEC och CENELEC är organiserat.

Arbetet i de tekniska kommittéerna är öppet för alla svenska organisationer, företag, institutioner, myndigheter och statliga verk. Den årliga avgiften för deltagandet och intäkter från försäljning finansierar SEKs standardiseringsverksamhet och medlemsavgift till IEC och CENELEC.

Var med och påverka!

Den som deltar i SEKs tekniska kommittéarbete har möjlighet att påverka framtida standarder och får tidig tillgång till information och dokumentation om utvecklingen inom sitt teknikområde. Arbetet och kontakterna med kollegor, kunder och konkurrenter kan gynnsamt påverka enskilda företags affärsutveckling och bidrar till deltagarnas egen kompetensutveckling.

Du som vill dra nytta av dessa möjligheter är välkommen att kontakta SEKs kansli för mer information.

SEK Svensk Elstandard

Box 1284
164 29 Kista
Tel 08-444 14 00
www.elstandard.se

ICS 35.020; 35.110; 35.160

English Version

Information technology - Data centre facilities and infrastructures - Part 2-3: Environmental control

Technologie de l'information - Installation et infrastructures
des centres de traitement de données - Partie 2-3: Contrôle
environnemental

Informationstechnik - Einrichtungen und Infrastrukturen von
Rechenzentren - Teil 2-3: Überwachung der Umgebung

This European Standard was approved by CENELEC on 2014-09-01. CENELEC members are bound to comply with the CEN/CENELEC Internal Regulations which stipulate the conditions for giving this European Standard the status of a national standard without any alteration.

Up-to-date lists and bibliographical references concerning such national standards may be obtained on application to the CEN-CENELEC Management Centre or to any CENELEC member.

This European Standard exists in three official versions (English, French, German). A version in any other language made by translation under the responsibility of a CENELEC member into its own language and notified to the CEN-CENELEC Management Centre has the same status as the official versions.

CENELEC members are the national electrotechnical committees of Austria, Belgium, Bulgaria, Croatia, Cyprus, the Czech Republic, Denmark, Estonia, Finland, Former Yugoslav Republic of Macedonia, France, Germany, Greece, Hungary, Iceland, Ireland, Italy, Latvia, Lithuania, Luxembourg, Malta, the Netherlands, Norway, Poland, Portugal, Romania, Slovakia, Slovenia, Spain, Sweden, Switzerland, Turkey and the United Kingdom.



European Committee for Electrotechnical Standardization
Comité Européen de Normalisation Electrotechnique
Europäisches Komitee für Elektrotechnische Normung

CEN-CENELEC Management Centre: Avenue Marnix 17, B-1000 Brussels

Contents

Page

Foreword	4
Introduction	5
1 Scope	7
2 Normative references	7
3 Terms, definitions and abbreviations	7
3.1 Terms and definitions	7
3.2 Abbreviations	9
4 Conformance	9
5 Environmental control within data centres	9
5.1 General	9
5.2 Environmental control of data centre spaces	10
6 Availability	14
6.1 General	14
6.2 Design options by space.....	14
6.3 Environmental control system capacity planning with respect to expansion.....	18
6.4 Environmental control system capacity planning with respect to resilience	18
7 Physical security	18
7.1 General	18
7.2 Access	18
8 Energy efficiency enablement	18
8.1 General	18
8.2 Measurement of temperature	19
8.3 Measurement of relative humidity.....	20
8.4 Measurement of air pressure.....	21
8.5 Coolant flow rates	21
8.6 Heat removal	21
8.7 Outside air.....	22
8.8 Provision of alarms	22
8.9 Measurement requirements by Granularity Level.....	22
Annex A (normative) Distribution methodologies for temperature-controlled air in computer room space	23
A.1 Cabinet or rack air flow management	23
A.2 Access floor air flow management	23
A.3 Hot aisles/cold aisles	24
Annex B (informative) Control system concepts	26
B.1 General	26
B.2 Control of exhaust temperature (return air)	26
B.3 Control of supply temperature (supply air)	26

B.4	Combination of control of supply and exhaust temperature	26
B.5	Supply air relative humidity	26
B.6	Proportion of outside air	26
	Bibliography.....	27

Foreword

This document (EN 50600-2-3:2014) has been prepared by CLC/TC 215 “Electrotechnical aspects of telecommunication equipment”.

The following dates are fixed:

- latest date by which this document has to be implemented at national level by publication of an identical national standard or by endorsement (dop) 2015-09-01
- latest date by which the national standards conflicting with this document have to be withdrawn (dow) 2017-09-01

Attention is drawn to the possibility that some of the elements of this document may be the subject of patent rights. CENELEC shall not be held responsible for identifying any or all such patent rights.

This document has been prepared under a mandate given to CENELEC by the European Commission and the European Free Trade Association.

Introduction

The unrestricted access to internet-based information demanded by the information society has led to an exponential growth of both internet traffic and the volume of stored/retrieved data. Data centres are housing and supporting the information technology and network telecommunications equipment for data processing, data storage and data transport. They are required both by network operators (delivering those services to customer premises) and by enterprises within those customer premises.

Data centres need to provide modular, scalable and flexible facilities and infrastructures to easily accommodate the rapidly changing requirements of the market. In addition, energy consumption of data centres has become critical both from an environmental point of view (reduction of carbon footprint) and with respect to economical considerations (cost of energy) for the data centre operator.

The implementation of data centres varies in terms of:

- a) purpose (enterprise, co-location, co-hosting or network operator facilities);
- b) security level;
- c) physical size;
- d) accommodation (mobile, temporary and permanent constructions).

The needs of data centres also vary in terms of availability of service, the provision of security and the objectives for energy efficiency. These needs and objectives influence the design of data centres in terms of building construction, power distribution, environmental control and physical security. Effective management and operational information is required to monitor achievement of the defined needs and objectives.

This series of European Standards specifies requirements and recommendations to support the various parties involved in the design, planning, procurement, integration, installation, operation and maintenance of facilities and infrastructures within data centres. These parties include:

- 1) owners, facility managers, ICT managers, project managers, main contractors;
- 2) architects, building designers and builders, system and installation designers;
- 3) facility and infrastructure integrators, suppliers of equipment;
- 4) installers, maintainers.

At the time of publication of this European Standard, the EN 50600 series will comprise the following standards:

- EN 50600-1, *Information technology — Data centre facilities and infrastructures — Part 1: General concepts*;
- EN 50600-2-1, *Information technology — Data centre facilities and infrastructures — Part 2-1: Building construction*;
- EN 50600-2-2, *Information technology — Data centre facilities and infrastructures — Part 2-2: Power distribution*;
- EN 50600-2-3, *Information technology — Data centre facilities and infrastructures — Part 2-3: Environmental control*;

- EN 50600-2-4, *Information technology — Data centre facilities and infrastructures — Part 2-4: Telecommunications cabling infrastructure*;
- EN 50600-2-5, *Information technology — Data centre facilities and infrastructures — Part 2-5: Security systems*;
- EN 50600-2-6, *Information technology — Data centre facilities and infrastructures — Part 2-6: Management and operational information*.

The inter-relationship of the standards within the EN 50600 series is shown in Figure 1.

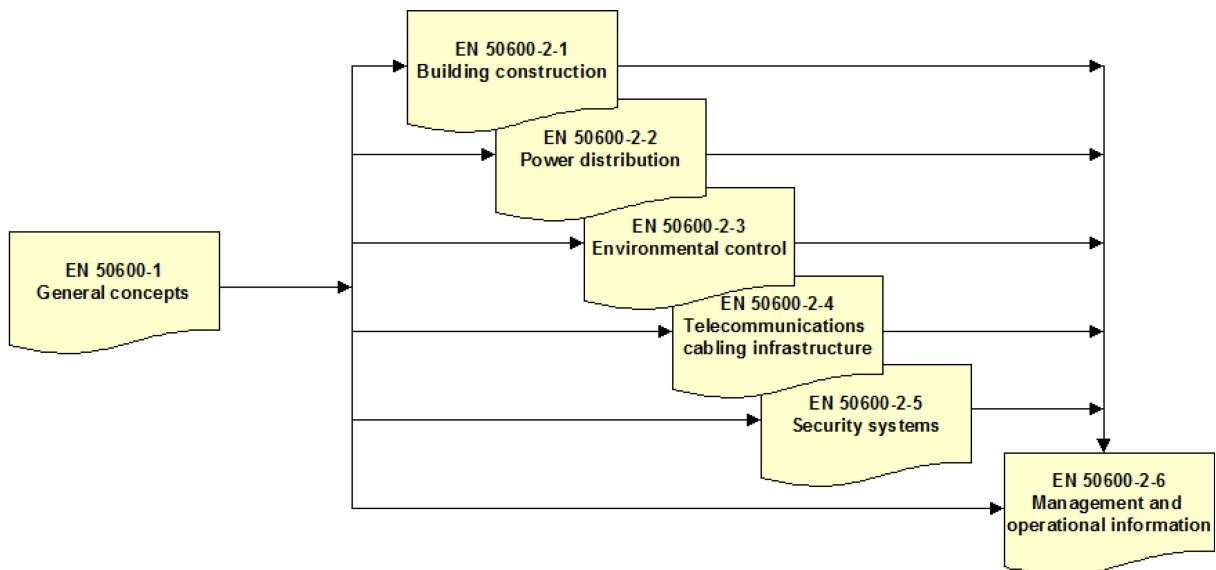

Figure 1 — Schematic relationship between the EN 50600 standards

EN 50600-2-X standards specify requirements and recommendations for particular facilities and infrastructures to support the relevant classification for “availability”, “physical security” and “energy efficiency enablement” selected from EN 50600-1.

This European Standard addresses the environmental control facilities and infrastructure within data centres together with the interfaces for monitoring the performance of those facilities and infrastructures in line with EN 50600-2-6 (in accordance with the requirements of EN 50600-1).

This series of European Standards does not address the selection of information technology and network telecommunications equipment, software and associated configuration issues.

1 Scope

This European Standard addresses environmental control within data centres based upon the criteria and classifications for “availability”, “security” and “energy efficiency enablement” within EN 50600-1.

This European Standard specifies requirements and recommendations for the following:

- a) temperature control,
- b) fluid movement control,
- c) relative humidity control,
- d) particulate control,
- e) vibration,
- f) floor layout and equipment locations,
- g) energy saving practices,
- h) physical security of environmental control systems.

For issues related to electromagnetic environment, see EN 50600-2-5.

2 Normative references

The following documents, in whole or in part, are normatively referenced in this document and are indispensable for its application. For dated references, only the edition cited applies. For undated references, the latest edition of the referenced document (including any amendments) applies.

EN 50600-1, *Information technology — Data centre facilities and infrastructures — Part 1: General concepts*

EN 50600-2-5¹⁾, *Information technology — Data centre facilities and infrastructures — Part 2-5: Security systems*

1) Circulated for CENELEC enquiry.