

© Copyright SEK Svensk Elstandard. Reproduction in any form without permission is prohibited.

Laddningsbara celler och batterier med alkalisk eller annan icke syrabaserad elektrolyt – Säkerhetsfordringar på litiumceller och litiumbatterier för elektriska energilagringssystem

*Secondary cells and batteries containing alkaline or other non-acid electrolytes –
Safety requirements for secondary lithium cells and batteries for use in electrical energy storage systems*

Som svensk standard gäller europastandarden EN IEC 63056:2020. Den svenska standarden innehåller den officiella engelska språkversionen av EN IEC 63056:2020.

Nationellt förord

Europastandarden EN IEC 63056:2020

består av:

- **europastandardens ikraftsättningsdokument**, utarbetat inom CENELEC
- **IEC 63056, First edition, 2020 - Secondary cells and batteries containing alkaline or other non-acid electrolytes - Safety requirements for secondary lithium cells and batteries for use in electrical energy storage systems**

utarbetad inom International Electrotechnical Commission, IEC.

ICS 29.220.30

Denna standard är fastställd av SEK Svensk Elstandard, som också kan lämna upplysningar om **sakinnehållet** i standarden.
Postadress: Box 1284, 164 29 KISTA
Telefon: 08 - 444 14 00.
E-post: sek@elstandard.se. Internet: www.elstandard.se

Standarder underlättar utvecklingen och höjer elsäkerheten

Det finns många fördelar med att ha gemensamma tekniska regler för bl a mätning, säkerhet och provning och för utförande, skötsel och dokumentation av elprodukter och elanläggningar.

Genom att utforma sådana standarder blir säkerhetsfordringar tydliga och utvecklingskostnaderna rimliga samtidigt som marknadens acceptans för produkten eller tjänsten ökar.

Många standarder inom elområdet beskriver tekniska lösningar och metoder som åstadkommer den elsäkerhet som föreskrivs av svenska myndigheter och av EU.

SEK är Sveriges röst i standardiseringsarbetet inom elområdet

SEK Svensk Elstandard svarar för standardiseringen inom elområdet i Sverige och samordnar svensk medverkan i internationell och europeisk standardisering. SEK är en ideell organisation med frivilligt deltagande från svenska myndigheter, företag och organisationer som vill medverka till och påverka utformningen av tekniska regler inom elektrotekniken.

SEK samordnar svenska intressenters medverkan i SEKs tekniska kommittéer och stödjer svenska experters medverkan i internationella och europeiska projekt.

Stora delar av arbetet sker internationellt

Utformningen av standarder sker i allt väsentligt i internationellt och europeiskt samarbete. SEK är svensk nationalkommitté av International Electrotechnical Commission (IEC) och Comité Européen de Normalisation Electrotechnique (CENELEC).

Standardiseringsarbetet inom SEK är organiserat i referensgrupper bestående av ett antal tekniska kommittéer som speglar hur arbetet inom IEC och CENELEC är organiserat.

Arbetet i de tekniska kommittéerna är öppet för alla svenska organisationer, företag, institutioner, myndigheter och statliga verk. Den årliga avgiften för deltagandet och intäkter från försäljning finansierar SEKs standardiseringsverksamhet och medlemsavgift till IEC och CENELEC.

Var med och påverka!

Den som deltar i SEKs tekniska kommittéarbete har möjlighet att påverka framtida standarder och får tidig tillgång till information och dokumentation om utvecklingen inom sitt teknikområde. Arbetet och kontakterna med kollegor, kunder och konkurrenter kan gynnsamt påverka enskilda företags affärsutveckling och bidrar till deltagarnas egen kompetensutveckling.

Du som vill dra nytta av dessa möjligheter är välkommen att kontakta SEKs kansli för mer information.

SEK Svensk Elstandard

Box 1284
164 29 Kista
Tel 08-444 14 00
www.elstandard.se

English Version

Secondary cells and batteries containing alkaline or other non-acid electrolytes - Safety requirements for secondary lithium cells and batteries for use in electrical energy storage systems
(IEC 63056:2020)

Accumulateurs alcalins et autres accumulateurs à électrolyte non acide - Exigences de sécurité pour les accumulateurs au lithium pour utilisation dans des systèmes de stockage d'énergie électrique
(IEC 63056:2020)

Sekundärzellen und -batterien mit alkalischen oder anderen nicht säurehaltigen Elektrolyten - Sicherheitsanforderungen für Lithium-Sekundärzellen und -batterien für die Verwendung in elektrischen Energiespeichersystemen
(IEC 63056:2020)

This European Standard was approved by CENELEC on 2020-05-01. CENELEC members are bound to comply with the CEN/CENELEC Internal Regulations which stipulate the conditions for giving this European Standard the status of a national standard without any alteration.

Up-to-date lists and bibliographical references concerning such national standards may be obtained on application to the CEN-CENELEC Management Centre or to any CENELEC member.

This European Standard exists in three official versions (English, French, German). A version in any other language made by translation under the responsibility of a CENELEC member into its own language and notified to the CEN-CENELEC Management Centre has the same status as the official versions.

CENELEC members are the national electrotechnical committees of Austria, Belgium, Bulgaria, Croatia, Cyprus, the Czech Republic, Denmark, Estonia, Finland, France, Germany, Greece, Hungary, Iceland, Ireland, Italy, Latvia, Lithuania, Luxembourg, Malta, the Netherlands, Norway, Poland, Portugal, Republic of North Macedonia, Romania, Serbia, Slovakia, Slovenia, Spain, Sweden, Switzerland, Turkey and the United Kingdom.



European Committee for Electrotechnical Standardization
Comité Européen de Normalisation Electrotechnique
Europäisches Komitee für Elektrotechnische Normung

CEN-CENELEC Management Centre: Rue de la Science 23, B-1040 Brussels

European foreword

The text of document 21A/718/FDIS, future edition 1 of IEC 63056, prepared by SC 21A "Secondary cells and batteries containing alkaline or other non-acid electrolytes" of IEC/TC 21 "Secondary cells and batteries" was submitted to the IEC-CENELEC parallel vote and approved by CENELEC as EN IEC 63056:2020.

The following dates are fixed:

- latest date by which the document has to be implemented at national level by publication of an identical national standard or by endorsement (dop) 2021-02-01
- latest date by which the national standards conflicting with the document have to be withdrawn (dow) 2023-05-01

Attention is drawn to the possibility that some of the elements of this document may be the subject of patent rights. CENELEC shall not be held responsible for identifying any or all such patent rights.

Endorsement notice

The text of the International Standard IEC 63056:2020 was approved by CENELEC as a European Standard without any modification.

In the official version, for Bibliography, the following notes have to be added for the standards indicated:

IEC 61434	NOTE	Harmonized as EN 61434
IEC 61960-3	NOTE	Harmonized as EN 61960-3
IEC 62368-1:2018	NOTE	Harmonized as EN IEC 62368-1:2020 (not modified)

Annex ZA (normative)

Normative references to international publications with their corresponding European publications

The following documents are referred to in the text in such a way that some or all of their content constitutes requirements of this document. For dated references, only the edition cited applies. For undated references, the latest edition of the referenced document (including any amendments) applies.

NOTE 1 Where an International Publication has been modified by common modifications, indicated by (mod), the relevant EN/HD applies.

NOTE 2 Up-to-date information on the latest versions of the European Standards listed in this annex is available here: www.cenelec.eu.

<u>Publication</u>	<u>Year</u>	<u>Title</u>	<u>EN/HD</u>	<u>Year</u>
IEC 60050-482	-	International Electrotechnical Vocabulary - Part 482: Primary and secondary cells and batteries	-	-
IEC 60695-10-2	-	Fire hazard testing - Part 10-2: Abnormal heat - Ball pressure test method	EN 60695-10-2	-
IEC 60695-11-10	-	Fire hazard testing - Part 11-10: Test flames - 50 W horizontal and vertical flame test methods	EN 60695-11-10	-
IEC 60950-1 (mod)	2005	Information technology equipment - Safety - Part 1: General requirements	EN 60950-1 + A11 + A12 + AC	2006 2009 2011 2011
IEC 62619	-	Secondary cells and batteries containing alkaline or other non-acid electrolytes - Safety requirements for secondary lithium cells and batteries, for use in industrial applications	-	-
IEC 62620	2014	Secondary cells and batteries containing alkaline or other non-acid electrolytes - Secondary lithium cells and batteries for use in industrial applications	EN 62620	2015
ISO/IEC Guide 51	-	Safety aspects - Guidelines for their inclusion in standards	-	-

CONTENTS

FOREWORD.....	3
INTRODUCTION.....	5
1 Scope.....	6
2 Normative references	7
3 Terms and definitions	7
4 Parameter measurement tolerances	9
5 General safety considerations	10
5.1 General.....	10
5.2 Insulation and wiring	10
5.3 The peak voltage of charging	11
6 Type test conditions	11
6.1 General.....	11
6.2 Test items	11
7 Specific requirements and tests	12
7.1 Basic requirement.....	12
7.2 Resistance to abnormal heat.....	12
7.3 Casing material of a battery system that can be transported for installation or maintenance	12
7.4 Electric insulation check during transport and installation.....	12
7.5 Charging procedures for test purposes	13
7.6 Protection against short circuit during transport and installation	13
7.7 Protection for reverse connection.....	13
7.8 Overdischarge control of voltage (battery system).....	14
7.9 Drop test.....	14
7.9.1 General	14
7.9.2 Whole drop test	15
7.9.3 Edge and corner drop test	15
8 Information for Safety	16
9 Marking and designation.....	16
Annex A (informative) Wiring, connections and supply	17
Bibliography.....	18
Figure 1 – IEC 62619 as umbrella standard to various industrial applications.....	5
Figure 2 – Scope of IEC 63056	6
Figure 3 – Impact location.....	15
Figure 4 – Configuration for the shortest edge drop test.....	16
Figure 5 – Configuration for the corner drop test.....	16
Table 1 – Type test	12
Table 2 – Drop test method and condition	14
Table A.1 – IEC 60950-1:2005 subclauses addressing wiring, connections and supply	17
Table A.2 – Wiring, connections and supply, as addressed in IEC 62368-1	17

INTERNATIONAL ELECTROTECHNICAL COMMISSION

**SECONDARY CELLS AND BATTERIES CONTAINING ALKALINE OR OTHER
NON-ACID ELECTROLYTES – SAFETY REQUIREMENTS FOR SECONDARY
LITHIUM CELLS AND BATTERIES FOR USE IN ELECTRICAL ENERGY
STORAGE SYSTEMS**

FOREWORD

- 1) The International Electrotechnical Commission (IEC) is a worldwide organization for standardization comprising all national electrotechnical committees (IEC National Committees). The object of IEC is to promote international co-operation on all questions concerning standardization in the electrical and electronic fields. To this end and in addition to other activities, IEC publishes International Standards, Technical Specifications, Technical Reports, Publicly Available Specifications (PAS) and Guides (hereafter referred to as "IEC Publication(s)"). Their preparation is entrusted to technical committees; any IEC National Committee interested in the subject dealt with may participate in this preparatory work. International, governmental and non-governmental organizations liaising with the IEC also participate in this preparation. IEC collaborates closely with the International Organization for Standardization (ISO) in accordance with conditions determined by agreement between the two organizations.
- 2) The formal decisions or agreements of IEC on technical matters express, as nearly as possible, an international consensus of opinion on the relevant subjects since each technical committee has representation from all interested IEC National Committees.
- 3) IEC Publications have the form of recommendations for international use and are accepted by IEC National Committees in that sense. While all reasonable efforts are made to ensure that the technical content of IEC Publications is accurate, IEC cannot be held responsible for the way in which they are used or for any misinterpretation by any end user.
- 4) In order to promote international uniformity, IEC National Committees undertake to apply IEC Publications transparently to the maximum extent possible in their national and regional publications. Any divergence between any IEC Publication and the corresponding national or regional publication shall be clearly indicated in the latter.
- 5) IEC itself does not provide any attestation of conformity. Independent certification bodies provide conformity assessment services and, in some areas, access to IEC marks of conformity. IEC is not responsible for any services carried out by independent certification bodies.
- 6) All users should ensure that they have the latest edition of this publication.
- 7) No liability shall attach to IEC or its directors, employees, servants or agents including individual experts and members of its technical committees and IEC National Committees for any personal injury, property damage or other damage of any nature whatsoever, whether direct or indirect, or for costs (including legal fees) and expenses arising out of the publication, use of, or reliance upon, this IEC Publication or any other IEC Publications.
- 8) Attention is drawn to the Normative references cited in this publication. Use of the referenced publications is indispensable for the correct application of this publication.
- 9) Attention is drawn to the possibility that some of the elements of this IEC Publication may be the subject of patent rights. IEC shall not be held responsible for identifying any or all such patent rights.

International Standard IEC 63056 has been prepared by subcommittee 21A: Secondary cells and batteries containing alkaline or other non-acid electrolytes, of IEC technical committee 21: Secondary cells and batteries.

The text of this International Standard is based on the following documents:

FDIS	Report on voting
21A/718/FDIS	21A/723/RVD

Full information on the voting for the approval of this International Standard can be found in the report on voting indicated in the above table.

This document has been drafted in accordance with the ISO/IEC Directives, Part 2.

The committee has decided that the contents of this document will remain unchanged until the stability date indicated on the IEC website under "<http://webstore.iec.ch>" in the data related to the specific document. At this date, the document will be

- reconfirmed,
- withdrawn,
- replaced by a revised edition, or
- amended.

IMPORTANT – The 'colour inside' logo on the cover page of this publication indicates that it contains colours which are considered to be useful for the correct understanding of its contents. Users should therefore print this document using a colour printer.

INTRODUCTION

This document covers safety requirements for secondary lithium cells and batteries for use in Electrical Energy Storage Systems and is under the umbrella standard IEC 62619 as shown in Figure 1. As an umbrella standard, IEC 62619 had been developed which covered various industrial applications in 2017.

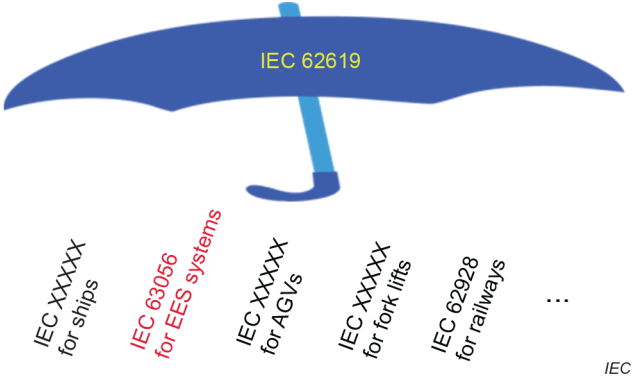

Figure 1 – IEC 62619 as umbrella standard to various industrial applications

SECONDARY CELLS AND BATTERIES CONTAINING ALKALINE OR OTHER NON-ACID ELECTROLYTES – SAFETY REQUIREMENTS FOR SECONDARY LITHIUM CELLS AND BATTERIES FOR USE IN ELECTRICAL ENERGY STORAGE SYSTEMS

1 Scope

This document specifies requirements and tests for the product safety of secondary lithium cells and batteries used in electrical energy storage systems (Figure 2) with a maximum DC voltage of 1 500 V (nominal).

Basic safety requirements for the secondary lithium cells and batteries used in industrial applications are included in IEC 62619. This document provides additional or specific requirements for electrical energy storage systems.

Since this document covers batteries for various electrical energy storage systems, it includes those requirements which are common and minimum to the electrical energy storage systems.

Examples of appliances that are within the scope of this document are:

- telecommunications,
- central emergency lighting and alarm systems,
- stationary engine starting,
- photovoltaic systems,
- home (residential) energy storage systems (HESS), and
- large energy storage: on-grid/off-grid.

This document applies to cells and batteries for uninterruptible power supplies (UPS).

This document does not apply to portable systems 500 Wh or below, which are covered by IEC 61960-3.

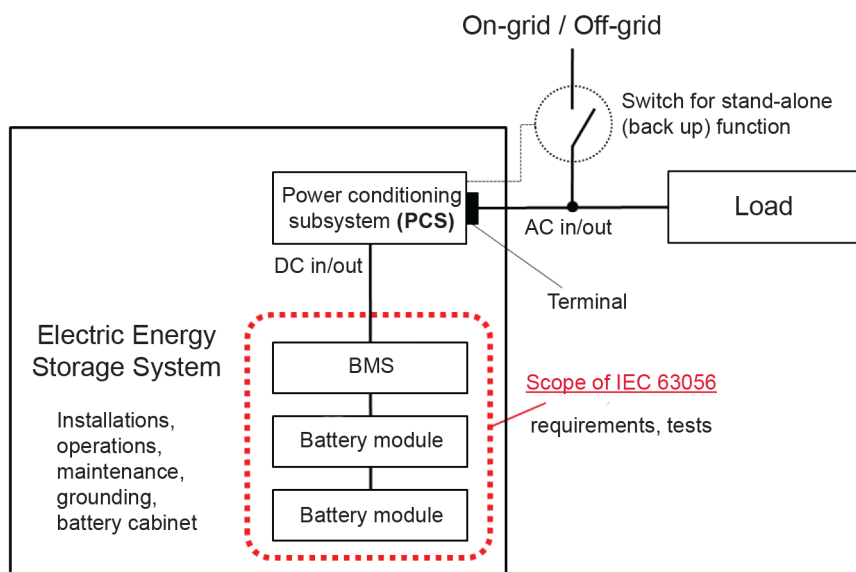

IEC

Figure 2 – Scope of IEC 63056

2 Normative references

The following documents, in whole or in part, are normatively referenced in this document and are indispensable for its application. For dated references, only the edition cited applies. For undated references, the latest edition of the referenced document (including any amendments) applies.

IEC 60050-482, *International Electrotechnical Vocabulary (IEV) – Part 482: Primary and secondary cells and batteries* (available at <http://www.electropedia.org/>)

IEC 60695-10-2, *Fire hazard testing – Part 10-2: Abnormal heat – Ball pressure test method*

IEC 60695-11-10, *Fire hazard testing – Part 11-10: Test flames – 50 W horizontal and vertical flame test methods*

IEC 60950-1:2005, *Information technology equipment – Safety – Part 1: General requirements*

IEC 62619, *Secondary cells and batteries containing alkaline or other non-acid electrolytes – Safety requirements for secondary lithium cells and batteries, for use in industrial applications*

IEC 62620:2014, *Secondary cells and batteries containing alkaline or other non-acid electrolytes – Secondary lithium cells and batteries for use in industrial applications*

ISO/IEC Guide 51, *Safety aspects – Guidelines for their inclusion in standards*