

© Copyright SEK Svensk Elstandard. Reproduction in any form without permission is prohibited.

## **Bränsleceller – Del 8-201: Energilagringssystem med bränslecellsmoduler för reversibel drift – Provning av prestanda för stationära system för energilagring**

*Fuel cell technologies –*

*Part 8-201: Energy storage systems using fuel cell modules in reverse mode –  
Test procedures for the performance of power-to-power systems*

Som svensk standard gäller europastandarden EN IEC 62282-8-201:2020. Den svenska standarden innehåller den officiella engelska språkversionen av EN IEC 62282-8-201:2020.

### **Nationellt förord**

Europastandarden EN IEC 62282-8-201:2020

består av:

- **europastandardens ikraftsättningsdokument**, utarbetat inom CENELEC
- **IEC 62282-8-201, First edition, 2020 - Fuel cell technologies - Part 8-201: Energy storage systems using fuel cell modules in reverse mode - Test procedures for the performance of power-to-power systems**

utarbetad inom International Electrotechnical Commission, IEC.

---

ICS 27.070.00

---

Denna standard är fastställd av SEK Svensk Elstandard, som också kan lämna upplysningar om **sakinnehållet** i standarden.  
Postadress: Box 1284, 164 29 KISTA  
Telefon: 08 - 444 14 00.  
E-post: sek@elstandard.se. Internet: www.elstandard.se

---

### *Standarder underlättar utvecklingen och höjer elsäkerheten*

Det finns många fördelar med att ha gemensamma tekniska regler för bl a mätning, säkerhet och provning och för utförande, skötsel och dokumentation av elprodukter och elanläggningar.

Genom att utforma sådana standarder blir säkerhetsfordringar tydliga och utvecklingskostnaderna rimliga samtidigt som marknadens acceptans för produkten eller tjänsten ökar.

Många standarder inom elområdet beskriver tekniska lösningar och metoder som åstadkommer den elsäkerhet som föreskrivs av svenska myndigheter och av EU.

### *SEK är Sveriges röst i standardiseringsarbetet inom elområdet*

SEK Svensk Elstandard svarar för standardiseringen inom elområdet i Sverige och samordnar svensk medverkan i internationell och europeisk standardisering. SEK är en ideell organisation med frivilligt deltagande från svenska myndigheter, företag och organisationer som vill medverka till och påverka utformningen av tekniska regler inom elektrotekniken.

SEK samordnar svenska intressenters medverkan i SEKs tekniska kommittéer och stödjer svenska experters medverkan i internationella och europeiska projekt.

### *Stora delar av arbetet sker internationellt*

Utformningen av standarder sker i allt väsentligt i internationellt och europeiskt samarbete. SEK är svensk nationalkommitté av International Electrotechnical Commission (IEC) och Comité Européen de Normalisation Electrotechnique (CENELEC).

Standardiseringsarbetet inom SEK är organiserat i referensgrupper bestående av ett antal tekniska kommittéer som speglar hur arbetet inom IEC och CENELEC är organiserat.

Arbetet i de tekniska kommittéerna är öppet för alla svenska organisationer, företag, institutioner, myndigheter och statliga verk. Den årliga avgiften för deltagandet och intäkter från försäljning finansierar SEKs standardiseringsverksamhet och medlemsavgift till IEC och CENELEC.

### *Var med och påverka!*

Den som deltar i SEKs tekniska kommittéarbete har möjlighet att påverka framtida standarder och får tidig tillgång till information och dokumentation om utvecklingen inom sitt teknikområde. Arbetet och kontakterna med kollegor, kunder och konkurrenter kan gynnsamt påverka enskilda företags affärsutveckling och bidrar till deltagarnas egen kompetensutveckling.

Du som vill dra nytta av dessa möjligheter är välkommen att kontakta SEKs kansli för mer information.

### **SEK Svensk Elstandard**

Box 1284  
164 29 Kista  
Tel 08-444 14 00  
[www.elstandard.se](http://www.elstandard.se)

English Version

Fuel cell technologies - Part 8-201: Energy storage systems  
using fuel cell modules in reverse mode - Test procedures for  
the performance of power-to-power systems  
(IEC 62282-8-201:2020)

Technologies des piles à combustible - Partie 8-201:  
Systèmes de stockage de l'énergie utilisant des modules à  
piles à combustible en mode inversé - Procédures d'essai  
pour la performance des systèmes électriques à électriques  
(IEC 62282-8-201:2020)

Brennstoffzellentechnologien – Teil 8-201:  
Energiespeichersysteme mit Brennstoffzellenmodulen im  
reversiblen Betrieb – Prüfverfahren zum Leistungsverhalten  
von Power-to-Power-Systemen  
(IEC 62282-8-201:2020)

This European Standard was approved by CENELEC on 2020-02-14. CENELEC members are bound to comply with the CEN/CENELEC Internal Regulations which stipulate the conditions for giving this European Standard the status of a national standard without any alteration.

Up-to-date lists and bibliographical references concerning such national standards may be obtained on application to the CEN-CENELEC Management Centre or to any CENELEC member.

This European Standard exists in three official versions (English, French, German). A version in any other language made by translation under the responsibility of a CENELEC member into its own language and notified to the CEN-CENELEC Management Centre has the same status as the official versions.

CENELEC members are the national electrotechnical committees of Austria, Belgium, Bulgaria, Croatia, Cyprus, the Czech Republic, Denmark, Estonia, Finland, France, Germany, Greece, Hungary, Iceland, Ireland, Italy, Latvia, Lithuania, Luxembourg, Malta, the Netherlands, Norway, Poland, Portugal, Republic of North Macedonia, Romania, Serbia, Slovakia, Slovenia, Spain, Sweden, Switzerland, Turkey and the United Kingdom.



European Committee for Electrotechnical Standardization  
Comité Européen de Normalisation Electrotechnique  
Europäisches Komitee für Elektrotechnische Normung

CEN-CENELEC Management Centre: Rue de la Science 23, B-1040 Brussels

## **European foreword**

The text of document 105/764/FDIS, future edition 1 of IEC 62282-8-201, prepared by IEC/TC 105 "Fuel cell technologies" was submitted to the IEC-CENELEC parallel vote and approved by CENELEC as EN IEC 62282-8-201:2020.

The following dates are fixed:

- latest date by which the document has to be implemented at national level by publication of an identical national standard or by endorsement (dop) 2020-11-14
- latest date by which the national standards conflicting with the document have to be withdrawn (dow) 2023-02-14

Attention is drawn to the possibility that some of the elements of this document may be the subject of patent rights. CENELEC shall not be held responsible for identifying any or all such patent rights.

## **Endorsement notice**

The text of the International Standard IEC 62282-8-201:2020 was approved by CENELEC as a European Standard without any modification.

In the official version, for Bibliography, the following notes have to be added for the standards indicated:

IEC 60079-0	NOTE	Harmonized as EN IEC 60079-0
IEC 60079-10-1	NOTE	Harmonized as EN 60079-10-1
IEC 60079-29-2	NOTE	Harmonized as EN 60079-29-2
IEC 60364 series	NOTE	Harmonized as HD 60364 series
IEC 61000-4-7	NOTE	Harmonized as EN 61000-4-7
IEC 61000-4-13	NOTE	Harmonized as EN 61000-4-13
IEC 61960-3	NOTE	Harmonized as EN 61960-3
IEC 61987-1	NOTE	Harmonized as EN 61987-1
IEC 62282-2	NOTE	Harmonized as EN 62282-2
IEC 62282-3-100	NOTE	Harmonized as EN 62282-3-100
IEC 62282-3-300	NOTE	Harmonized as EN 62282-3-300
IEC 62933-1:2018	NOTE	Harmonized as EN IEC 62933-1:2018 (not modified)
ISO 15839	NOTE	Harmonized as EN ISO 15839

## Annex ZA (normative)

### Normative references to international publications with their corresponding European publications

The following documents are referred to in the text in such a way that some or all of their content constitutes requirements of this document. For dated references, only the edition cited applies. For undated references, the latest edition of the referenced document (including any amendments) applies.

NOTE 1 Where an International Publication has been modified by common modifications, indicated by (mod), the relevant EN/HD applies.

NOTE 2 Up-to-date information on the latest versions of the European Standards listed in this annex is available here: [www.cenelec.eu](http://www.cenelec.eu).

<u>Publication</u>	<u>Year</u>	<u>Title</u>	<u>EN/HD</u>	<u>Year</u>
IEC 61427-1	-	Secondary cells and batteries for renewable energy storage - General requirements and methods of test - Part 1: Photovoltaic off-grid application	EN 61427-1	-
IEC 61427-2	-	Secondary cells and batteries for renewable energy storage - General requirements and methods of test - Part 2: On-grid applications	EN 61427-2	-
IEC 62282-3-200	-	Fuel cell technologies - Part 3-200: Stationary fuel cell power systems - Performance test methods	EN 62282-3-200	-
IEC 62282-3-201	-	Fuel cell technologies - Part 3-201: Stationary fuel cell power systems - Performance test methods for small fuel cell power systems	EN 62282-3-201	-
IEC 62282-8-101	-	Fuel cell technologies - Part 8-101: Energy storage systems using fuel cell modules in reverse mode - Test procedures for the performance of solid oxide single cells and stacks, including reversible operation	-	-
IEC 62282-8-102	-	Fuel cell technologies - Part 8-102: Energy storage systems using fuel cell modules in reverse mode - Test procedures for the performance of single cells and stacks with proton exchange membrane, including reversible operation	EN IEC 62282-8-102 <sup>1</sup>	-
IEC 62933-2-1	2017	Electrical energy storage (EES) systems - Part 2-1: Unit parameters and testing methods - General specification	EN IEC 62933-2-1	2018

---

<sup>1</sup> To be published. Stage at the time of publication: prEN IEC 62282-8-102:2018.

## EN IEC 62282-8-201:2020 (E)

ISO/IEC Guide 98-3	-	Uncertainty of measurement - Part 3: Guide to the expression of uncertainty in measurement (GUM:1995)	-	-
ISO 3746	-	Acoustics - Determination of sound power levels and sound energy levels of noise sources using sound pressure - Survey method using an enveloping measurement surface over a reflecting plane	EN ISO 3746	-
ISO 4064-1	-	Water meters for cold potable water and hot water - Part 1: Metrological and technical requirements	EN ISO 4064-1	-
ISO 4064-2	-	Water meters for cold potable water and hot water - Part 2: Test methods	EN ISO 4064-2	-
ISO 7888	-	Water quality - Determination of electrical conductivity	EN 27888	-
ISO 9614-1	-	Acoustics - Determination of sound power levels of noise sources using sound intensity - Part 1: Measurement at discrete points	EN ISO 9614-1	-
ISO 11204	-	Acoustics - Noise emitted by machinery and equipment - Determination of emission sound pressure levels at a work station and at other specified positions applying accurate environmental corrections	EN ISO 11204	-
ISO 16111	-	Transportable gas storage devices - Hydrogen absorbed in reversible metal hydride	-	-
ISO 19880-1	-	Gaseous hydrogen - Fuelling stations - Part 1: General requirements	-	-
ISO 19881	-	Gaseous hydrogen - Land vehicle fuel containers	-	-
ISO 19882	-	Gaseous hydrogen - Thermally activated pressure relief devices for compressed hydrogen vehicle fuel containers	-	-
ISO 19884	-	Gaseous hydrogen - Cylinders and tubes for stationary storage	EN ISO 19884 <sup>2</sup>	-
ISO 22734-1	-	Hydrogen generators using water electrolysis process - Part 1: Industrial and commercial applications	-	-
ISO 22734-2	-	Hydrogen generators using water electrolysis process - Part 2: Residential applications	-	-

---

<sup>2</sup> To be published. Stage at the time of publication: FprEN ISO 19884:2019.

## CONTENTS

FOREWORD.....	4
INTRODUCTION.....	6
1 Scope.....	7
2 Normative references .....	8
3 Terms, definitions and symbols .....	9
3.1 Terms and definitions.....	9
3.2 Symbols.....	13
4 Measurement instruments and measurement methods.....	14
4.1 General.....	14
4.2 Instrument uncertainty .....	15
4.3 Measurement plan .....	15
4.4 Environmental conditions .....	16
4.5 Maximum permissible variation in test operating conditions .....	17
5 System parameters.....	17
5.1 General.....	17
5.2 Electric energy storage capacity .....	17
5.3 Rated electric power input .....	18
5.4 Rated net electric power output.....	18
5.5 Roundtrip electrical efficiency .....	18
5.6 System response (step response time and ramp rate).....	18
5.6.1 Step response time.....	18
5.6.2 Ramp rate .....	19
5.7 Minimum switchover time .....	20
5.8 Quiescent state loss rate .....	20
5.9 Heat input rate .....	20
5.10 Recovered heat output rate.....	20
5.11 Acoustic noise level .....	20
5.12 Total harmonic distortion.....	20
5.13 Discharge water quality.....	21
6 Test methods and procedures .....	21
6.1 General.....	21
6.2 Electric energy storage capacity test.....	21
6.3 Rated electric power input test.....	22
6.4 Rated net electric power output test.....	22
6.5 Roundtrip electrical efficiency test .....	23
6.6 Other system performance test .....	23
6.6.1 System response test, step response time and ramp rate .....	23
6.6.2 Minimum switchover time test.....	25
6.6.3 Quiescent state loss rate test .....	25
6.6.4 Heat input rate test .....	26
6.6.5 Recovered heat output rate test.....	26
6.6.6 Acoustic noise level test .....	26
6.6.7 Total harmonic distortion test.....	27
6.6.8 Discharge water quality test.....	27
6.7 Component performance test .....	27
6.7.1 Electrolyser performance test .....	27

6.7.2	Hydrogen storage performance test .....	28
6.7.3	Fuel cell performance test .....	28
6.7.4	Water management system performance test .....	29
6.7.5	Battery performance test .....	29
6.7.6	Oxygen storage performance test .....	29
7	Test reports .....	29
7.1	General.....	29
7.2	Report items .....	29
7.3	Tested system data description.....	30
7.4	Test condition description .....	30
7.5	Test data description .....	30
7.6	Uncertainty evaluation .....	30
	Bibliography.....	31
	Figure 1 – System configuration of electric energy storage system using hydrogen – Type with electrolyser and fuel cell.....	7
	Figure 2 – System configuration of electric energy storage system using hydrogen – Type with reversible cell .....	8
	Figure 3 – Typical sequence of phases during the system operation .....	16
	Figure 4 – Step response time and ramp rate of EES system.....	19
	Figure 5 – Step response test .....	24
	Figure 6 – Minimum switch over time test .....	25
	Table 1 – Symbols .....	14
	Table 2 – Required steps before executing the measurement .....	16
	Table 3 – Example of document format of roundtrip electrical efficiency.....	23
	Table 4 – Additional parameters measured on the electrolyser or the reversible cell module in electrolysis mode.....	27
	Table 5 – Additional parameters measured on the hydrogen storage component .....	28
	Table 6 – Additional parameters measured on the fuel cell or the reversible cell module in fuel cell mode .....	28



## INTERNATIONAL ELECTROTECHNICAL COMMISSION

## FUEL CELL TECHNOLOGIES –

**Part 8-201: Energy storage systems using fuel cell modules in reverse mode – Test procedures for the performance of power-to-power systems**

## FOREWORD

- 1) The International Electro technical Commission (IEC) is a worldwide organization for standardization comprising all national electro technical committees (IEC National Committees). The object of IEC is to promote international co-operation on all questions concerning standardization in the electrical and electronic fields. To this end and in addition to other activities, IEC publishes International Standards, Technical Specifications, Technical Reports, Publicly Available Specifications (PAS) and Guides (hereafter referred to as "IEC Publication(s)"). Their preparation is entrusted to technical committees; any IEC National Committee interested in the subject dealt with may participate in this preparatory work. International, governmental and non-governmental organizations liaising with the IEC also participate in this preparation. IEC collaborates closely with the International Organization for Standardization (ISO) in accordance with conditions determined by agreement between the two organizations.
- 2) The formal decisions or agreements of IEC on technical matters express, as nearly as possible, an international consensus of opinion on the relevant subjects since each technical committee has representation from all interested IEC National Committees.
- 3) IEC Publications have the form of recommendations for international use and are accepted by IEC National Committees in that sense. While all reasonable efforts are made to ensure that the technical content of IEC Publications is accurate, IEC cannot be held responsible for the way in which they are used or for any misinterpretation by any end user.
- 4) In order to promote international uniformity, IEC National Committees undertake to apply IEC Publications transparently to the maximum extent possible in their national and regional publications. Any divergence between any IEC Publication and the corresponding national or regional publication shall be clearly indicated in the latter.
- 5) IEC itself does not provide any attestation of conformity. Independent certification bodies provide conformity assessment services and, in some areas, access to IEC marks of conformity. IEC is not responsible for any services carried out by independent certification bodies.
- 6) All users should ensure that they have the latest edition of this publication.
- 7) No liability shall attach to IEC or its directors, employees, servants or agents including individual experts and members of its technical committees and IEC National Committees for any personal injury, property damage or other damage of any nature whatsoever, whether direct or indirect, or for costs (including legal fees) and expenses arising out of the publication, use of, or reliance upon, this IEC Publication or any other IEC Publications.
- 8) Attention is drawn to the normative references cited in this publication. Use of the referenced publications is indispensable for the correct application of this publication.
- 9) Attention is drawn to the possibility that some of the elements of this IEC Publication may be the subject of patent rights. IEC shall not be held responsible for identifying any or all such patent rights.

International Standard IEC 62282-8-201 has been prepared by IEC technical committee 105: Fuel cell technologies.

The text of this International Standard is based on the following documents:

FDIS	Report on voting
105/764/FDIS	105/777/RVD

Full information on the voting for the approval of this International Standard can be found in the report on voting indicated in the above table.

This document has been drafted in accordance with the ISO/IEC Directives, Part 2.

A list of all parts in the IEC 62282 series, published under the general title *Fuel cell technologies*, can be found on the IEC website.

The committee has decided that the contents of this document will remain unchanged until the stability date indicated on the IEC website under "<http://webstore.iec.ch>" in the data related to the specific document. At this date, the document will be

- reconfirmed,
- withdrawn,
- replaced by a revised edition, or
- amended.

**IMPORTANT – The 'colour inside' logo on the cover page of this publication indicates that it contains colours which are considered to be useful for the correct understanding of its contents. Users should therefore print this document using a colour printer.**

## INTRODUCTION

This part of IEC 62282 describes performance evaluation methods for electric energy storage systems using hydrogen that employ electrochemical reactions both for water/steam electrolysis and electric generation.

This document is intended for power to power systems which typically employ a set of electrolyser and fuel cell, or a reversible cell for devices of electric charge and discharge.

A typical targeting application of the electric energy storage systems using hydrogen is in the class of energy intensive electric energy storage. The systems are recognized as critically useful for the relatively long-term power storage operation, such as efficient storage and supply of the renewable power derived electric energy and grid stabilization.

IEC 62282-8 (all parts) aims to develop performance test methods for power storage and buffering systems based on electrochemical modules (combining electrolysis and fuel cells, in particular reversible cells), taking into consideration both options of re-electrification and substance (and heat) production for sustainable integration of renewable energy sources.

Under the general title *Energy storage systems using fuel cell modules in reverse mode*, the IEC 62282-8 series consists of the following parts:

- IEC 62282-8-101: *Test procedures for the performance of solid oxide single cells and stacks, including reversible operation*
- IEC 62282-8-102: *Test procedures for the performance of single cells and stacks with proton exchange membranes, including reversible operation*
- IEC 62282-8-103<sup>1</sup>: *Alkaline single cell and stack performance including reversible operation*
- IEC 62282-8-201: *Test procedures for the performance of power-to-power systems*
- IEC 62282-8-202<sup>2</sup>: *Power-to-power systems – Safety*
- IEC 62282-8-300 (all parts)<sup>3</sup>: *Power-to-substance systems*

As a priority dictated by the emerging needs for industry and opportunities for technological development, IEC 62282-8-101, IEC 62282-8-102 and IEC 62282-8-201 have been initiated jointly and firstly. These parts are presented as a package to highlight the need for an integrated approach as regards the system's application (i.e. a solution for energy storage) and its fundamental constituent components (i.e. fuel cells operated in reverse or reversing mode).

IEC 62282-8-103, IEC 62282-8-202 and IEC 62282-8-300 (all parts) are suggested but are left for initiation at a later stage.

---

<sup>1</sup> Under consideration.

<sup>2</sup> Under consideration.

<sup>3</sup> Under consideration.

## FUEL CELL TECHNOLOGIES –

### Part 8-201: Energy storage systems using fuel cell modules in reverse mode – Test procedures for the performance of power-to-power systems

#### 1 Scope

This part of IEC 62282 defines the evaluation methods of typical performances for electric energy storage systems using hydrogen. This is applicable to the systems that use electrochemical reaction devices for both power charge and discharge. This document applies to systems that are designed and used for service and operation in stationary locations (indoor and outdoor).

The conceptual configurations of the electric energy storage systems using hydrogen are shown in Figure 1 and Figure 2. Figure 1 shows the system independently equipped with an electrolyser module and a fuel cell module. Figure 2 shows the system equipped with a reversible cell module. There are an electrolyser, a hydrogen storage and a fuel cell, or a reversible cell, a hydrogen storage and an overall management system (which may include a pressure management) as indispensable components. There may be a battery, an oxygen storage, a heat management system (which may include a heat storage) and a water management system (which may include a water storage) as optional components. The performance measurement is executed in the area surrounded by the outside thick solid line square (system boundary).

NOTE In the context of this document, the term "reversible" does not refer to the thermodynamic meaning of an ideal process. It is common practice in the fuel cell community to call the operation mode of a cell that alternates between fuel cell mode and electrolysis mode "reversible".

This document is intended to be used for data exchanges in commercial transactions between the system manufacturers and customers. Users of this document can selectively execute test items suitable for their purposes from those described in this document.

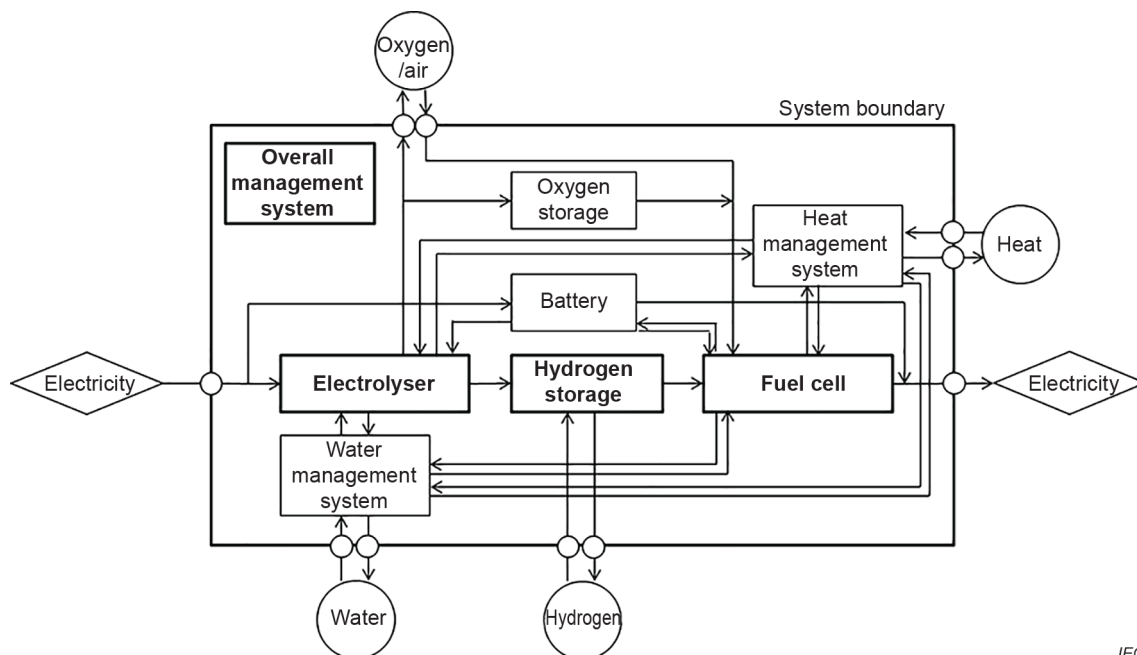

IEC

**Figure 1 – System configuration of electric energy storage system using hydrogen – Type with electrolyser and fuel cell**

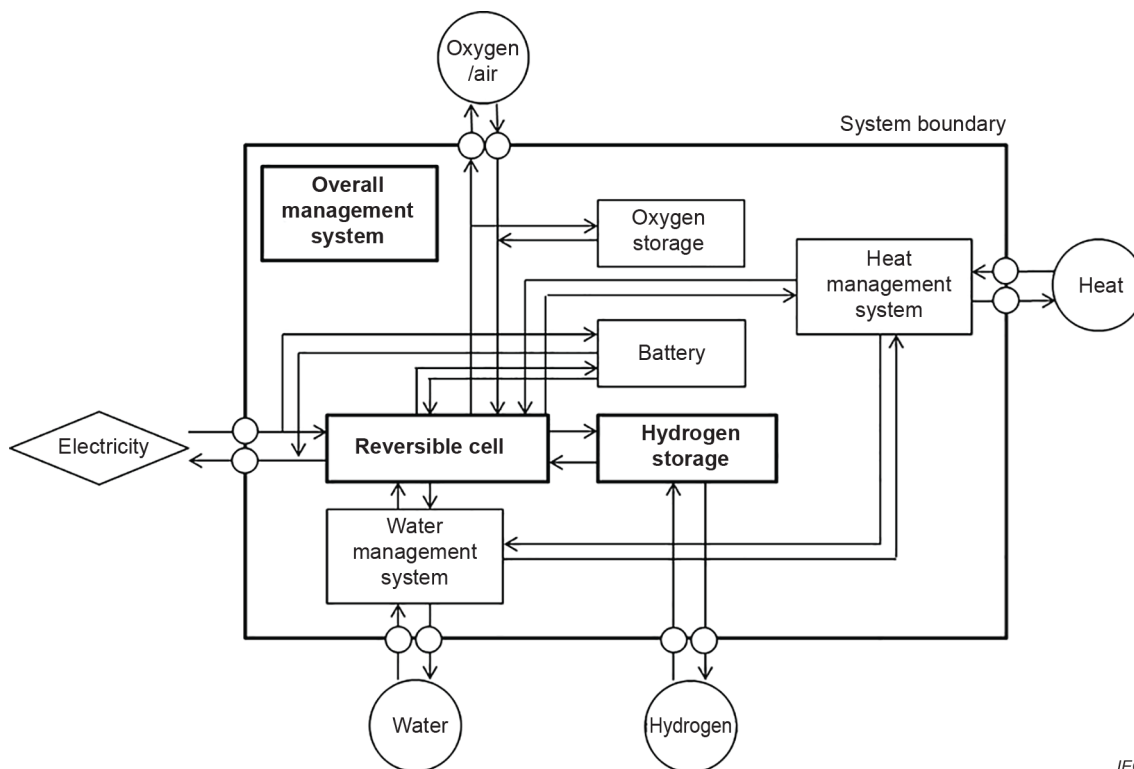

IEC

**Figure 2 – System configuration of electric energy storage system using hydrogen  
– Type with reversible cell**

## 2 Normative references

The following documents are referred to in the text in such a way that some or all of their content constitutes requirements of this document. For dated references, only the edition cited applies. For undated references, the latest edition of the referenced document (including any amendments) applies.

IEC 61427-1, *Secondary cells and batteries for renewable energy storage – General requirements and methods of test – Part 1: Photovoltaic off-grid application*

IEC 61427-2, *Secondary cells and batteries for renewable energy storage – General requirements and methods of test – Part 2: On-grid applications*

IEC 62282-3-200, *Fuel cell technologies – Part 3-200: Stationary fuel cell power systems – Performance test methods*

IEC 62282-3-201, *Fuel cell technologies – Part 3-201: Stationary fuel cell power systems – Performance test methods for small fuel cell power systems*

IEC 62282-8-101, *Fuel cell technologies – Part 8-101: Energy storage systems using fuel cell modules in reverse mode – Solid oxide single cell and stack performance including reversible operation*

IEC 62282-8-102, *Fuel cell technologies – Part 8-102: Energy storage systems using fuel cell modules in reverse mode – Test procedures for PEM single cell and stack performance including reversible operation*

IEC 62933-2-1:2017, *Electrical energy storage (EES) systems – Part 2-1: Unit parameters and testing methods – General specification*

ISO/IEC Guide 98-3, *Uncertainty of measurement – Part 3: Guide to the expression of uncertainty in measurement (GUM:1995)*

ISO 3746, *Acoustics – Determination of sound power levels and sound energy levels of noise sources using sound pressure – Survey method using an enveloping measurement surface over a reflecting plane*

ISO 4064-1, *Water meters for cold potable water and hot water – Part 1: Metrological and technical requirements*

ISO 4064-2, *Water meters for cold potable water and hot water – Part 2: Test methods*

ISO 7888, *Water quality – Determination of electrical conductivity*

ISO 9614-1, *Acoustics – Determination of sound power levels of noise sources using sound intensity – Part 1: Measurement at discrete points*

ISO 11204, *Acoustics – Noise emitted by machinery and equipment – Determination of emission sound pressure levels at a work station and at other specified positions applying accurate environmental corrections*

ISO 16111, *Transportable gas storage devices – Hydrogen absorbed in reversible metal hydride*

ISO 19880-1, *Gaseous hydrogen – Fuelling stations – Part 1: General requirements*

ISO 19881, *Gaseous hydrogen – Land vehicle fuel containers*

ISO 19882, *Gaseous hydrogen – Thermally activated pressure relief devices for compressed hydrogen vehicle fuel containers*

ISO 19884, *Gaseous hydrogen – Cylinders and tubes for stationary storage*

ISO 22734-1, *Hydrogen generators using water electrolysis process – Part 1: Industrial and commercial applications*

ISO 22734-2, *Hydrogen generators using water electrolysis process – Part 2: Residential applications*